

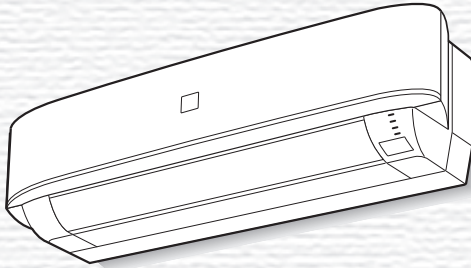

SHARP®



**SPLIT TYPE
ROOM AIR CONDITIONER
OPERATION MANUAL**

ENGLISH

Uses Refrigerant R410A

ECO INVERTER

INDOOR UNIT

**AH-PNX21
AH-PNX25**

OUTDOOR UNIT

**AU-PNX21
AU-PNX25**



Device of this mark is a trademark of Sharp Corporation. Plasmacluster is a registered trademark or a trademark of Sharp Corporation.

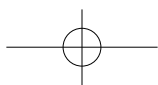
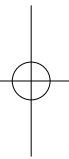
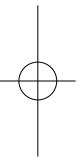
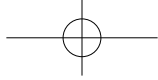

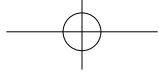

ENGLISH

Please read this manual carefully before using the product. This manual should be kept in a safe place for handy reference.

CONTENTS

- IMPORTANT SAFETY INSTRUCTIONSEN-1
- PART NAMES.....EN-2
- USING THE REMOTE CONTROLEN-4
- AUXILIARY MODEEN-4
- TIPS ON SAVING ENERGYEN-4
- BASIC OPERATIONEN-5
- ADJUSTING THE AIR FLOW DIRECTIONEN-6
- SUPER JET OPERATIONEN-6
- GENTLE COOL AIREN-7
- PLASMACLUSTER OPERATIONEN-7
- SELF CLEAN OPERATIONEN-8
- ONE-HOUR OFF TIMER.....EN-8
- TIMER OPERATION.....EN-9
- POWER CONSUMPTION INDICATOR.....EN-10
- INSTANT LOW WATTAGE OPERATION ...EN-10
- MAINTENANCEEN-11
- BEFORE CALLING FOR SERVICEEN-12
- OPERATING CONDITION.....EN-12

IMPORTANT SAFETY INSTRUCTIONS

WARNINGS

- Do not pull or deform the power supply cord. Pulling and misuse of the power supply cord can result in damage to the unit and cause electrical shock.
- Be careful not to expose your body directly to the outlet air for a long time. It may affect your physical conditions.
- When using the air conditioner for infants, children, elderly, bedridden, or disabled people make sure the room temperature is suitable for those in the room.
- Never insert objects into the unit. Inserting objects can result in injury due to the high speed rotation of internal fans.
- Ground the air conditioner without fail. Do not connect the grounding wire to gas pipe, water pipe, lightning rod or telephone grounding wire. Incomplete grounding may cause electric shock.
- If anything is abnormal with the air conditioner (ex. a burning smell), stop the operation immediately and turn the circuit breaker OFF.
- The appliance shall be installed in accordance with national wiring regulations. Improper cable connection can cause the power supply cord, plug and the electrical outlet to overheat and cause fire.
- If the supply cord is damaged, it must be replaced by the manufacturer or its service agent or a similarly qualified person in order to avoid a hazard. Use only the manufacturer-specified power cord for replacement.

- Do not splash or pour water directly on the unit. Water can cause electrical shock or equipment damage.
- Do not attempt to install/remove/repair the unit by yourself. Incorrect work will cause electric shock, water leak, fire etc. Consult your dealer or other qualified service personnel for the installation/removal/repair of the unit.

CAUTIONS

- Open a window or door periodically to ventilate the room, especially when using gas appliances. Insufficient ventilation may cause oxygen shortage.
- Do not operate the buttons with wet hand. It may cause electric shock.
- For safety, turn the circuit breaker off when not using the unit for an extended period of time.
- Check the outdoor unit mounting rack periodically for wear and to make sure it is firmly in place.
- Do not put anything on the outdoor unit nor step on it. The object or the person may fall down or drop, causing injury.
- This unit is designed for residential use. Do not use for other applications such as in a kennel or greenhouse to raise animals or grow plants.
- Do not place a vessel with water on the unit. If water penetrates into the unit, electrical insulations may deteriorate and cause electric shock.
- Do not block the air inlets nor outlets of the unit. It may cause insufficient performance or troubles.
- Be sure to stop the operation and turn the circuit breaker off before performing any maintenance or cleaning. A fan is rotating inside the unit and you may get injured.
- This appliance is not intended for use by young children or infirm persons without supervision. Young children should be supervised to ensure that they do not play with the appliance.
- Make sure to connect the air conditioner to power supply of the rated voltage and frequency. Use of a power supply with improper voltage and frequency can result in equipment damage and possible fire.
- Do not install the unit in a place where inflammable gas may leak. It may cause fire. Install the unit in a place with minimal dust, fumes and moisture in the air.
- Arrange the drain hose to ensure smooth drainage. Insufficient drainage may cause wetting of the room, furniture etc.
- Make sure a leak breaker or a circuit breaker is installed, depending on the installation location, to avoid electrical shock.

ENGLISH

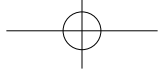

PART NAMES

INDOOR UNIT

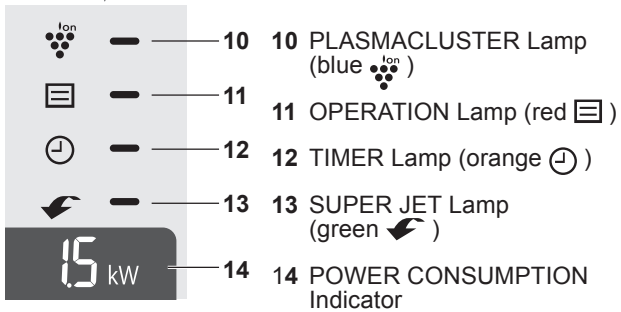
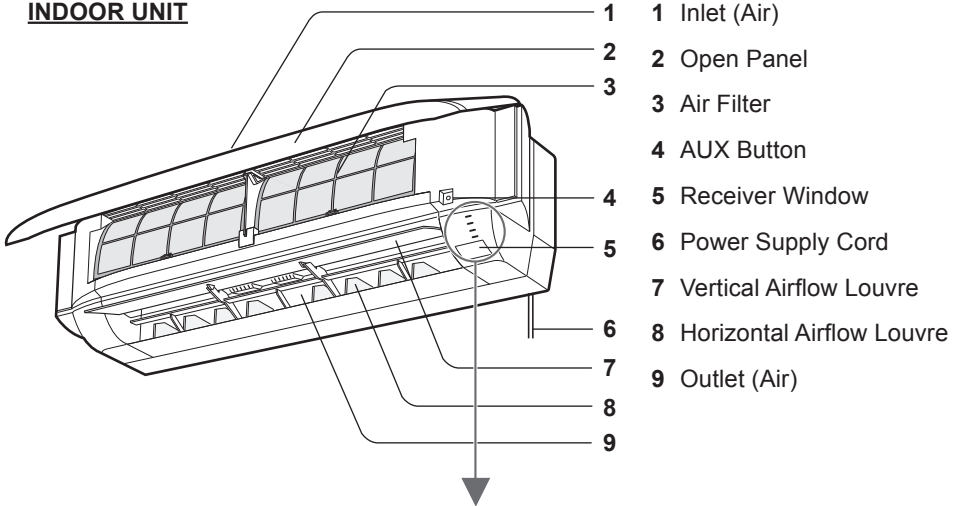

OUTDOOR UNIT

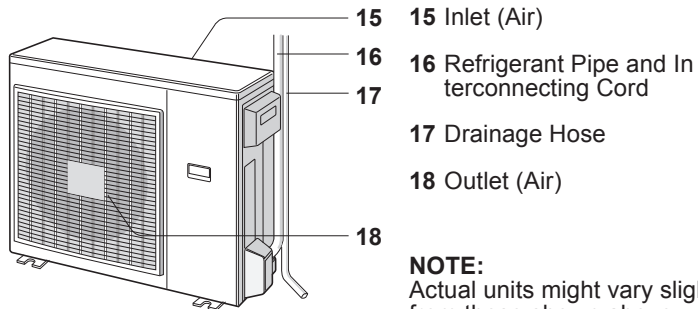

NOTE:
 Actual units might vary slightly from those shown above.

EN-2



ENGLISH

REMOTE CONTROL

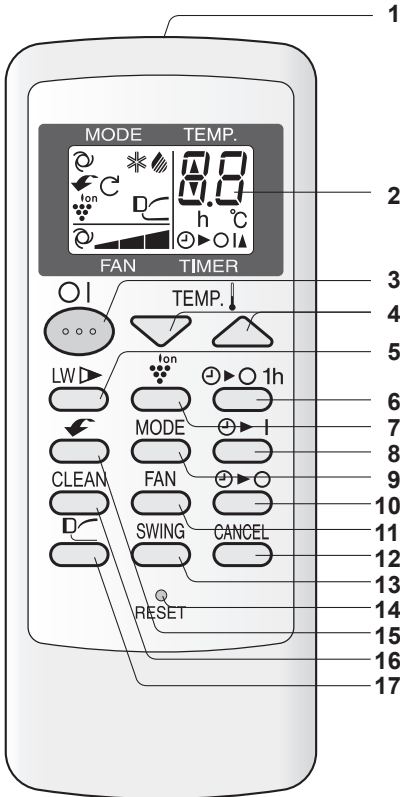

- 1 TRANSMITTER
- 2 DISPLAY
- 3 ON/OFF Button
- 4 THERMOSTAT Button
- 5 INSTANT LOW WATTAGE Button
- 6 ONE-HOUR OFF TIMER Button
- 7 PLASMACLUSTER Button
- 8 TIMER ON Button
- 9 MODE Button
- 10 TIMER OFF Button - SLEEP MODE
- 11 FAN Button
- 12 TIMER CANCEL Button
- 13 SWING Button
- 14 RESET Button
- 15 SUPER JET Button
- 16 SELF CLEAN Button
- 17 GENTLE COOL AIR Button

DISPLAY

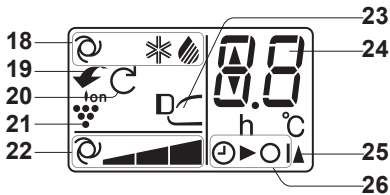

- 18 MODE Symbols
 - : AUTO
 - : COOL
 - : DRY
- 19 SUPER JET Symbol
- 20 SELF CLEAN Symbol
- 21 PLASMACLUSTER Symbol
- 22 FAN SPEED Symbols
 - : AUTO
 - : Manual setting
- 23 GENTLE COOL AIR Symbol
- 24 TEMPERATURE AND TIMER COUNT DOWN Indicator
- 25 TRANSMITTING Symbol
- 26 TIMER ON / TIMER OFF Indicator

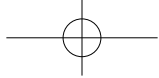

USING THE REMOTE CONTROL

LOADING BATTERIES

- 1** Remove the battery cover.
- 2** Insert two batteries. (AAA(R03))
Make sure the (+) and (-) polarities are correctly aligned.
- 3** Reinstall the battery cover.
- 4** Press the RESET button using a thin stick.

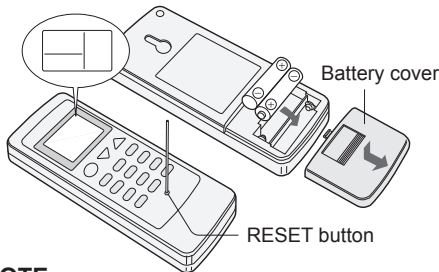

NOTE:

- The battery life is approximately 1 year in normal use.
- When replacing the batteries, always change both and use the same type.
- If you will not be using the unit for a long time, remove the batteries from the remote control.

HOW TO USE THE REMOTE CONTROL

Point the remote control towards the receiver window and press the desired button. The unit generates a beep when it receives the signal.

- Make sure nothing, such as curtains, block the signal receiver window.
- The signal effective distance is 7 m.

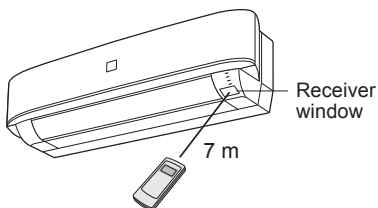

CAUTION:

- Do not expose the receiver window to direct sunlight. This may adversely affect its operation.
- Use of certain fluorescent lamp in the same room may interfere with transmission of the signal.
- Do not leave the remote control in direct sunlight or near a heater. Protect the remote control from moisture and shock.

AUXILIARY MODE

Use this mode when the remote control is not available.

TO TURN ON

Press the AUX button.

- The red OPERATION lamp () will light and the unit will start operating in the AUTO mode.
- The fan speed and temperature setting are set to AUTO.

TO TURN OFF

Press the AUX button again.

- The red OPERATION lamp () will turn off.

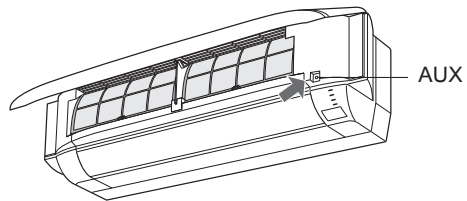

TIPS ON SAVING ENERGY

Below are some simple ways to save energy when you use your air conditioner.

Set the proper temperature

- Setting the temperature lower than necessary during cooling operation will result in increased power consumption.

Block direct sunlight and prevent drafts

- Blocking direct sunlight during cooling operation will reduce power consumption.
- Close the windows and doors during cooling operation.

Keep filter clean to ensure the most efficient operation

Disconnect the power cord when the unit is not used for an extended period of time

- The indoor unit still consumes a small amount of power when it is not operating.



BASIC OPERATION

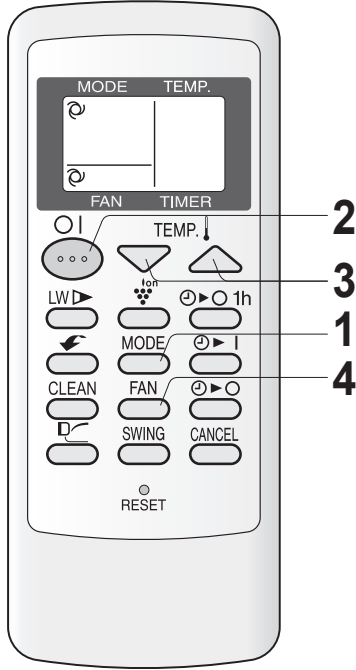

1 Press the **MODE** button to select the operation mode.

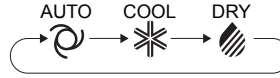

2 Press the **ON/OFF** button to start operation.

- The red OPERATION lamp () will light up.

TO TURN OFF

- Press the ON/OFF button again.
- The red OPERATION lamp () will turn off.

3 Press the **THERMOSTAT** button to set the desired temperature.

(AUTO/DRY mode)
The temperature can be changed up to ± 2 °C the automatically set of temperature.

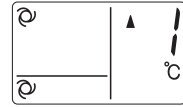

(COOL mode)
The temperature setting range: 16-30°C.

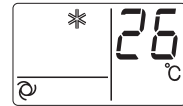

4 Press the **FAN** button to set the desired fan speed.

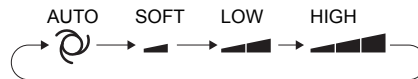

NOTE:

AUTO MODE

In the AUTO mode, the temperature setting and mode are automatically selected according to the room temperature when the unit is turned on.

DRY MODE

The fan speed is preset to AUTO and cannot be changed.

WHEN POWER FAILURE OCCURS

This air conditioner has a memory function to store settings when a power failure occurs. After power recovery, the unit will automatically re-start in the same settings which were active before the power failure, except for timer settings.

ENGLISH

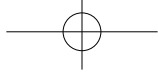

ADJUSTING THE AIR FLOW DIRECTION

VERTICAL AIR FLOW DIRECTION

1 Press the SWING button.

- The vertical airflow louver will swing.

2 Press the SWING button again to stop the desired position.

- The adjustment range is narrower than the swing range in order to prevent condensation from dripping.

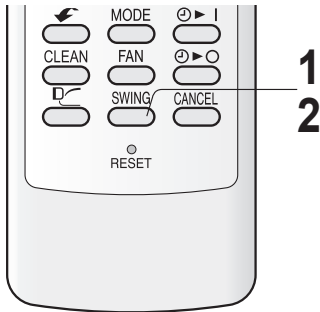

HORIZONTAL AIR FLOW DIRECTION

Hold the horizontal airflow louver lever and adjust the air flow direction.

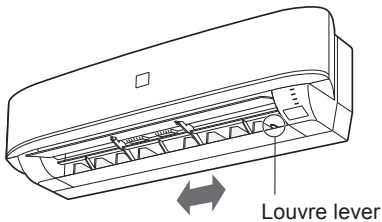

CAUTION:

Never attempt to adjust the vertical airflow louver manually.

- Manual adjustment of the vertical airflow louver can cause the unit to malfunction.
- When the vertical adjustment louver is positioned at the lowest position in the COOL or DRY mode for an extended period of time, condensation may result.

SUPER JET OPERATION

The air conditioner works at the maximum power and optimum louver direction to makes the room cool rapidly.

1 During operation, press the SUPER JET button.

- The remote control will display “) will light up.
- The vertical airflow louver will be set obliquely downward.

TO CANCEL

Press the SUPER JET button again.

- The green SUPER JET lamp (

NOTE:

- The air conditioner will operate at “Extra HIGH” fan speed for 15 minutes, and then shift to “HIGH” fan speed.
- You can not set the temperature or fan speed during the SUPER JET operation.

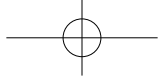

GENTLE COOL AIR

The vertical airflow louvre is set obliquely upward to deliver cool air to the ceiling in order to avoid direct airflow.

1 During operation, press the GENTLE COOL AIR button.

- The remote control will display “”.

TO CANCEL

Press the GENTLE COOL AIR button again.

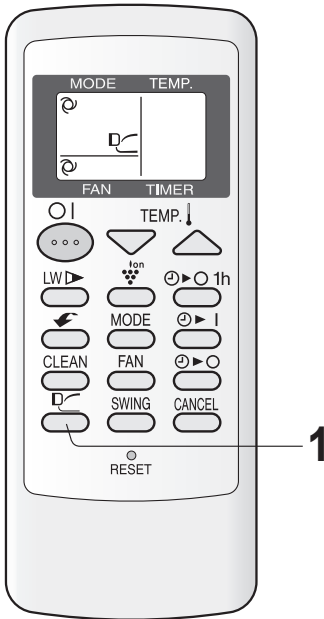



NOTE:

- If you want GENTLE COOL AIR operation in SUPER JET mode, press GENTLE COOL AIR button during SUPER JET operation.

PLASMACLUSTER OPERATION

Plasmacluster ions released into the room will reduce some airborne mold.

1 During operation, press the PLASMACLUSTER button.

- The remote control will display “”.
- The blue PLASMACLUSTER lamp () will light up.

TO CANCEL

Press the PLASMACLUSTER button again.

- The blue PLASMACLUSTER lamp () will turn off.

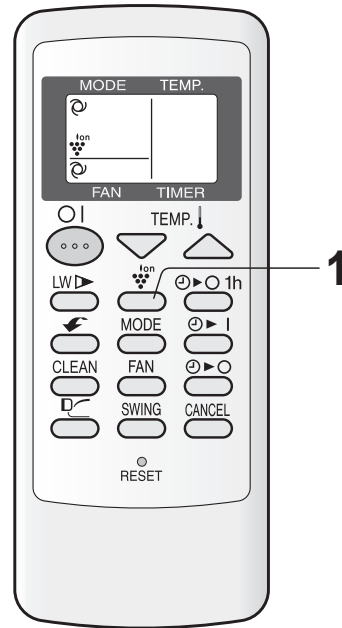

NOTE:

- Use of the PLASMACLUSTER operation will be memorized, and it will be activated the next time you turn on the unit.
- To perform Plasmacluster operation in FAN only mode, press the PLASMACLUSTER button when the unit is not operating. The mode symbol of the remote control will go off and the fan speed cannot be set to AUTO.



ENGLISH



SELF CLEAN OPERATION

SELF CLEAN operation will reduce the growth mold fungus with Plasmacluster ions and dry inside of the unit. Utilize the operation at seasonal change over terms or every 4 months.

1 Press the SELF CLEAN button when the unit is not operating.

- The remote control will display “”
- The blue PLASMACLUSTER lamp () will light up.
- The unit will stop operation after 40 minutes.

TO CANCEL

Press the SELF CLEAN button.

- The blue PLASMACLUSTER lamp () will turn off.

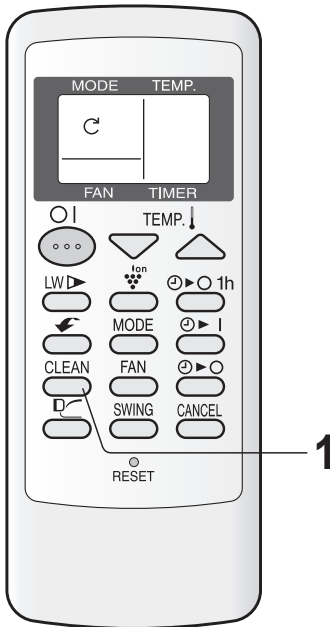



NOTE:

- You cannot set the temperature, fan speed, air flow direction or timer setting during the SELF CLEAN operation.
- Mold fungus already grown can not be eliminated by this operation.

ONE-HOUR OFF TIMER

When the ONE-HOUR OFF TIMER is set, the unit will automatically turn off after one hour.

1 Press the ONE-HOUR OFF TIMER button.

- The remote control will display “”.
- The orange TIMER lamp () will light up.

TO CANCEL

Press the CANCEL button.

- The orange TIMER lamp () will turn off.

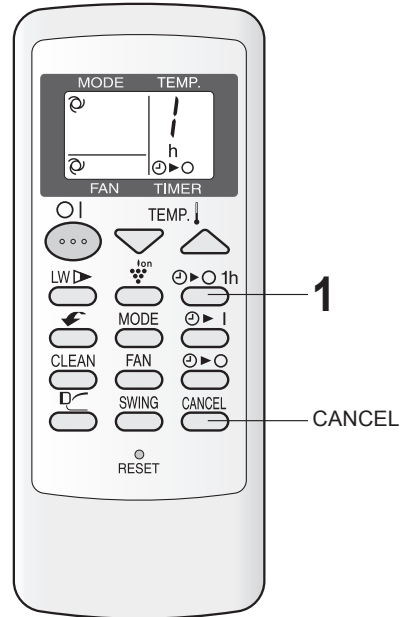

NOTE:

- The ONE-HOUR OFF TIMER operation has priority over TIMER ON and TIMER OFF operations.
- If the ONE-HOUR OFF TIMER is set while the unit is not operating, the unit will operate for an hour at the formerly set condition.
- If you wish to operate the unit for another hour before the ONE-HOUR OFF TIMER is activated, press the ONE-HOUR OFF TIMER button again during operation.

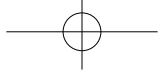

TIMER OPERATION

TIMER OFF - SLEEP MODE

- 1 Press the **TIMER OFF** button and set the time as desired.



- The orange **TIMER** lamp () will light up.
- The time setting will count down to show the remaining time.

TO CANCEL

Press the **CANCEL** button.

- The orange **TIMER** lamp () will turn off.

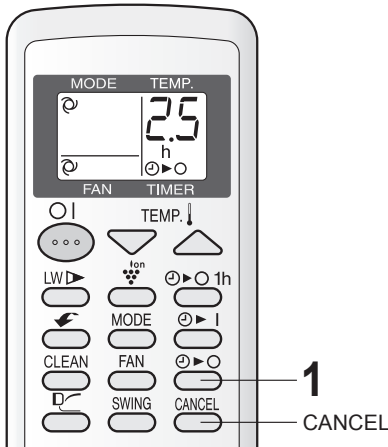

TIMER ON

- 1 Press the **TIMER ON** button and set the time as desired.



- The orange **TIMER** lamp () will light up.
- The time setting will count down to show the remaining time.

TO CANCEL

Press the **CANCEL** button.

- The orange **TIMER** lamp () will turn off.

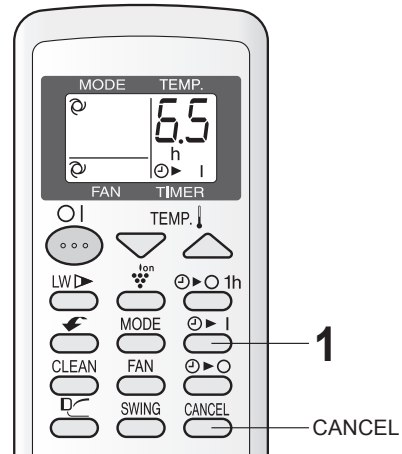

ENGLISH

NOTE:

- Timer duration can be set from a minimum half an hour to a maximum of 12 hours. Up to 9.5 hours, you can set in half-hour increments, and from 10 to 12 hours, in 1-hour increments.
- The **TIMER OFF** and **TIMER ON** can not be set together.
- The **ONE-HOUR OFF TIMER** operation has priority over **TIMER ON** and **TIMER OFF** operations.
- When the temperature is set during timer setting, the temperature will show in the display for 5 seconds and then return to the timer display.
- If a power failure occurs while the **TIMER** is set, the **TIMER** setting will be cancelled and will not be retrieved even after the power is restored.

TIMER OFF - SLEEP MODE

- When the **TIMER OFF** is set, the unit automatically adjusts the temperature setting to prevent excessive cooling while you are in sleep. One hour after the **TIMER OFF** is set, the unit gradually raises the temperature setting by 1°C by repeated **ON/OFF** operation for your comfortable sleep.

TIMER ON

- The unit will turn on prior to the set time to allow the room to reach the desired temperature by the programmed time. (Awaking function)

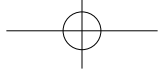

POWER CONSUMPTION INDICATOR

Indicates power consumption.

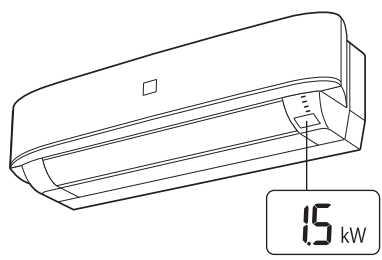

NOTE:

- After "H" is indicated in the first second, power consumption is indicated. (When INSTANT LOW WATTAGE is set, "L1" or "L2" is displayed first.)
- During PLASMACLUSTER operation at FAN mode and SELF CLEAN operation, power consumption will not be displayed.
- "0.1" is displayed on the indicator when the power consumption is less than 0.1 kW.

INSTANT LOW WATTAGE OPERATION

The air conditioner will operate with reduced maximum power and excess power consumption will be avoided.

1 During operation, press the INSTANT LOW WATTAGE button to select desired maximum wattage.

- The POWER CONSUMPTION indicator will change each time you press the button.

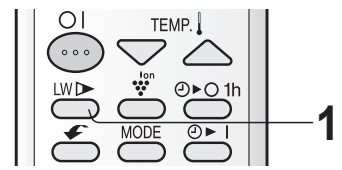

(AH-PNX21)

Maximum wattage	POWER CONSUMPTION indicator
Free	H → power consumption
1.0 kW	L1 → 10 → power consumption (When below 1.0 kW) (Blinking)
0.8 kW	L2 → 08 → power consumption (When below 0.8 kW) (Blinking)

(AH-PNX25)

Maximum wattage	POWER CONSUMPTION indicator
Free	H → power consumption
1.5 kW	L1 → 15 → power consumption (When below 1.5 kW) (Blinking)
1.0 kW	L2 → 10 → power consumption (When below 1.0 kW) (Blinking)

NOTE:

- The unit memorizes the previous INSTANT LOW WATTAGE setting and will be activated the next time operated.
- INSTANT LOW WATTAGE operation can not be available when the unit is in PLASMACLUSTER operation at FAN mode and SELF CLEAN operation.
- When power consumption is controlled by the INSTANT LOW WATTAGE function, "L1" or "L2" is displayed on the POWER CONSUMPTION indicator.



MAINTENANCE

Be sure to disconnect the power cord from the wall outlet or turn off the circuit breaker before performing any maintenance.

CLEANING THE FILTERS

1 Turn off the unit.

2 Remove the filters.

- ① Lift the open panel.
- ② Pull the air filters down to remove them.

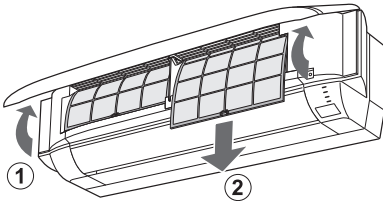

3 Clean the filters.

Use a vacuum cleaner to remove dust. If the filters are dirty, wash them with warm water and a mild detergent. Dry filters in the shade before reinstalling.

4 Reinstall the filters and close the open panel.

CLEANING THE UNIT AND THE REMOTE CONTROL

- Wipe them with a soft cloth.
- Do not directly splash or pour water on them. It can cause electrical shock or equipment damage.
- Do not use hot water, thinner, abrasive powders or strong solvents.

MAINTENANCE AFTER AIR CONDITIONER SEASON

- 1** Operate the unit in the SELF CLEAN operation to thoroughly dry inside the unit.
- 2** Stop the operation and unplug the unit. Turn off the circuit breaker, if you have one exclusively for the air conditioner.
- 3** Clean the filters, then reinstall them.

MAINTENANCE BEFORE AIR CONDITIONER SEASON

- 1** Make sure that the air filters are not dirty.
- 2** Make sure that nothing obstructs the air inlet or outlet.

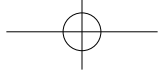

BEFORE CALLING FOR SERVICE

The following conditions do not denote equipment malfunctions

UNIT DOES NOT OPERATE

The unit will not operate if it is turned on immediately after it is turned off. The unit will not operate immediately after the mode is changed. This is to protect the unit. Wait 3 minutes before operating the unit.

ODORS

Carpet and furniture odors that entered into the unit may be sent out from the unit.

CRACKING NOISE

This sound is generated by the friction of the unit expanding or connecting due to a temperature change.

A LOW BUZZING NOISE

This is a sound of the unit generating Plasma-cluster ions.

SWISHING NOISE

The soft, swishing noise is the sound of the refrigerant flowing inside the unit.

MIST SEEN AT INDOOR AIR OUTLET

In cooling operation, this is caused by the difference between the room air temperature and the air discharged.

THE OUTDOOR UNIT DOES NOT STOP

After stopping the operation, the outdoor unit will rotate its fan for about a minute to cool down the unit.

ODOR EMITTED FROM THE PLASMACLUSTER AIR OUTLET

This is the smell of ozone generated from the Plasmacluster Ion generator. The ozone concentration is very small, posing no adverse effect on your health. The ozone discharged into the air rapidly decomposes, and its density in the room will not increase.

Check the following points before calling for service.

The unit does not operate

- Check if the circuit breaker has tripped or the fuse has blown.

The unit does not cool effectively

- Check the filters. If dirty, clean them.
- Check the outdoor unit to make sure nothing is blocking the air inlet or outlet.
- Check the thermostat is proper setting.
- Make sure windows and doors are closed tightly.

The unit does not receive the remote control signal

- Check whether the remote control batteries have become old and weak.
- Try to send the signal again with the remote control pointed properly towards the unit's signal receiver window.
- Check whether the remote control batteries are installed properly.

Please call for service when OPERATION lamp and TIMER lamp on the unit blink.

OPERATING CONDITION

Mode		Indoor Temp.	Outdoor Temp.
Cooling	Upper limit	32°C	43°C
	Lower limit	21°C	21°C

- The built-in safety device may prevent the unit from operating when used out of this range.
- Condensation may form on the air outlet if the unit operates continuously in the COOL or DRY mode when humidity is over 80 %.

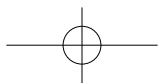
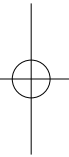
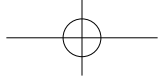

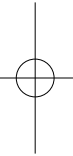
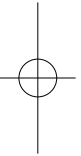
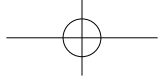

SHARP®

SHARP CORPORATION

Printed in Thailand
TINSEA728JBRZ 11L- ①

